

Turmdrehkran

Tower Crane / Grue à tour / Gru a torre / Grúa torre
Guindaste de torre / Башенный поворотный кран

280 HC-L 8/16 Litronic®

▶ 280 HC-L 8/16

280 HC-L 12/24

280 HC-L 16/28

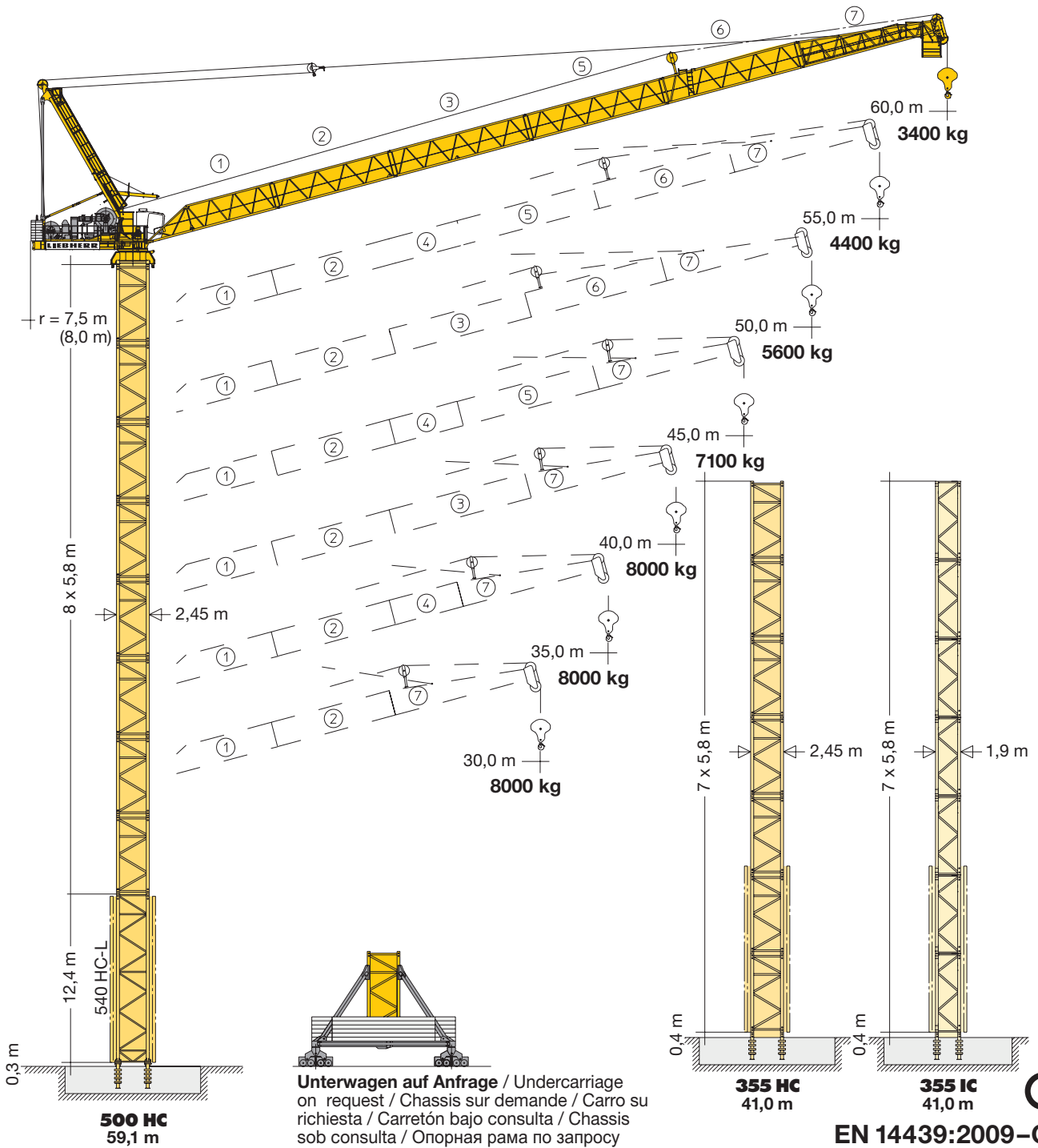

LIEBHERR

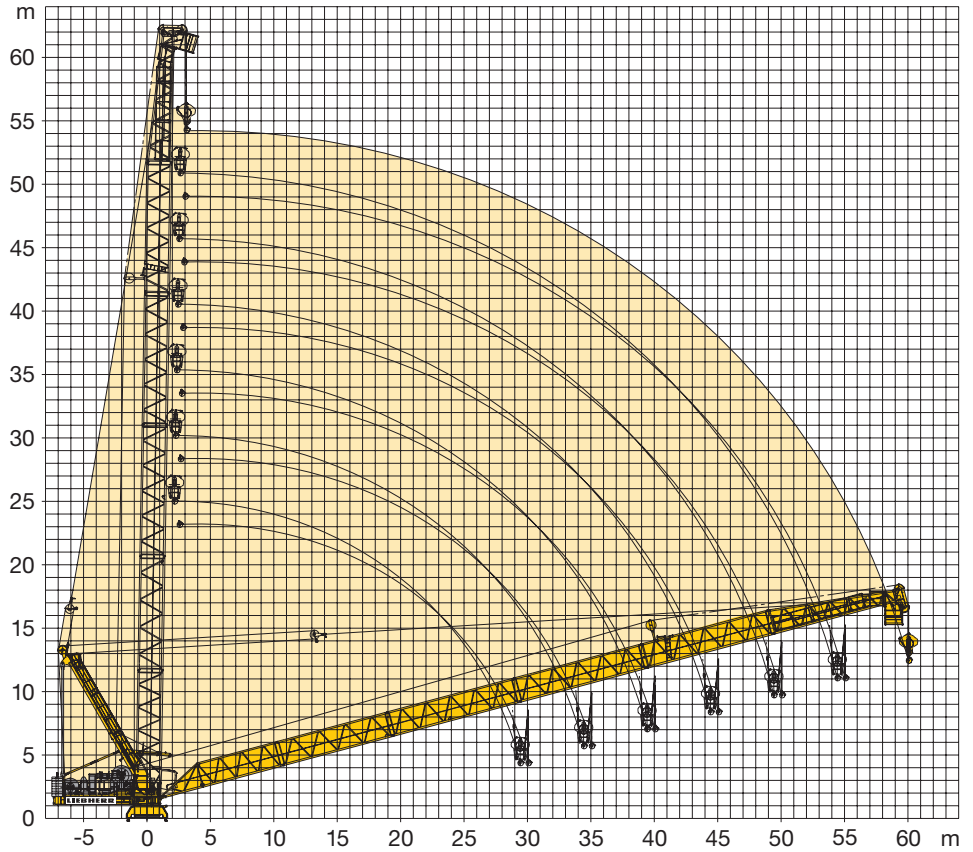

Turmhöhen

Tower heights / Hauteur de mât / Altezze torre / Alturas de torre / Alturas de torre / Высота башни

C 25	355 HC		500 HC			500 HC				355 IC		
	Ausleger / Jib / Flèche / Braccio / Pluma / Lança / Стрела											
	30,0 m	45,0 m	30,0 m	45,0 m	55,0 m	30,0 m	35,0 m	50,0 m	60,0 m	30,0 m	40,0 m	55,0 m
	35,0 m	50,0 m	35,0 m	45,0 m	60,0 m	40,0 m	45,0 m	55,0 m	60,0 m	50,0 m	55,0 m	60,0 m
	40,0 m	60,0 m	40,0 m	50,0 m	60,0 m	30,0 m	40,0 m	55,0 m	60,0 m	30,0 m	50,0 m	60,0 m
11	-	-	64,2*	-	-	76,5*	-	-	-	-	-	-
10	-	-	58,4	58,4*	-	70,7	70,7*	-	-	-	-	-
9	-	-	52,6	52,6	52,6*	64,9	64,9	64,9*	-	52,6*	-	-
8	46,8*	-	46,8	46,8	46,8	59,1	59,1	59,1	59,1*	46,8	46,8*	-
7	41,0	41,0*	41,0	41,0	41,0	53,3	53,3	53,3	53,3	41,0	41,0	41,0*
6	35,2	35,2	35,2	35,2	35,2	47,5	47,5	47,5	47,5	35,2	35,2	35,2
5	29,4	29,4	29,4	29,4	29,4	41,7	41,7	41,7	41,7	29,4	29,4	29,4
4	23,6	23,6	23,6	23,6	23,6	35,9	35,9	35,9	35,9	23,6	23,6	23,6
3	17,8	17,8	17,8	17,8	17,8	30,1	30,1	30,1	30,1	17,8	17,8	17,8
2	12,0	12,0	12,0	12,0	12,0	24,3	24,3	24,3	24,3	12,0	12,0	12,0
1	6,2	6,2	6,2	6,2	6,2	18,5	18,5	18,5	18,5	6,2	6,2	6,2
0	0,4	0,4	0,4	0,4	0,4	12,7	12,7	12,7	12,7	0,4	0,4	0,4
	m		m			m				m		



* Außer Betrieb, Auslegerstellung 15° – 70°. / Out of operation, jib position 15° – 70°. / Hors service, position de flèche 15° – 70°. / Fuori servizio, posizione braccio 15° – 70°. / Posición de pluma, fuera de servicio 15° – 70°. / Posição da lança, fora de serviço 15° – 70°. / Вне работы, положение стрелы под углом 15° – 70°.

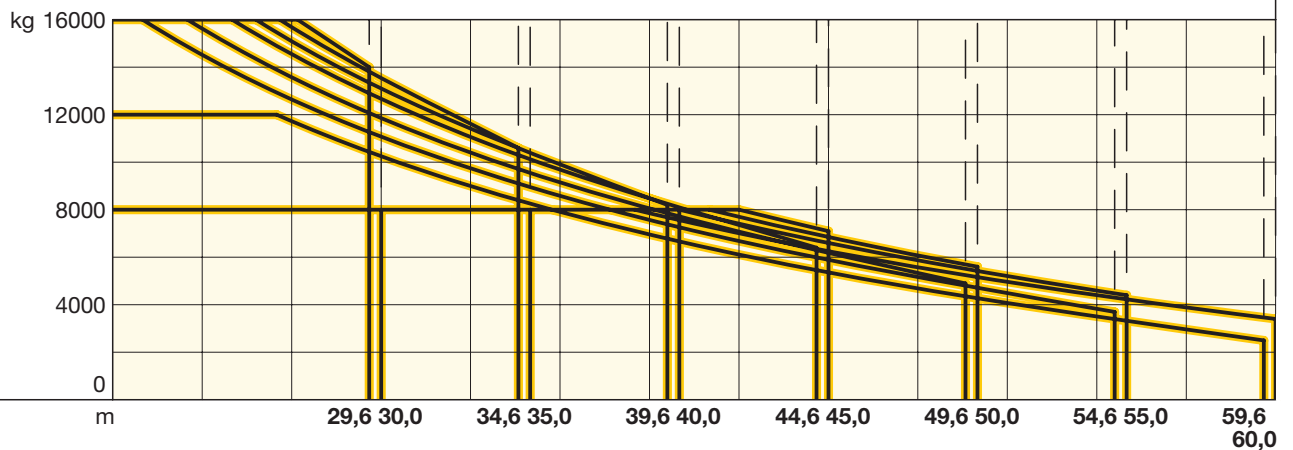

m		m/kg	m/kg								
			24,0	27,0	30,0	35,0	40,0	45,0	50,0	55,0	60,0
60,0	⊖	4,0 - 38,5 8000	8000	8000	8000	8000	7560	6260	5160	4230	3400
	⊕	4,0 - 26,5 12000	12000	11730	10250	8260	6670	5390	4270	3330	59,6 m 2500
55,0	⊖	4,0 - 40,0 8000	8000	8000	8000	8000	8000	6600	5420	4400	
	⊕	4,0 - 22,0 16000	14520	12640	11080	8960	7270	5880	4710	54,6 m 3700	
50,0	⊖	4,0 - 41,0 8000	8000	8000	8000	8000	8000	6850	5600		
	⊕	4,0 - 23,5 16000	15620	13570	11860	9550	7710	6190	49,6 m 4900		
45,0	⊖	4,0 - 42,0 8000	8000	8000	8000	8000	8000	7100			
	⊕	4,0 - 25,0 16000	16000	14550	12670	10130	8100	44,6 m 6400			
40,0	⊖	4,0 - 40,0 8000	8000	8000	8000	8000	8000				
	⊕	4,0 - 25,8 16000	16000	15100	13100	10400	39,6 m 8200				
35,0	⊖	4,0 - 35,0 8000	8000	8000	8000	8000					
	⊕	4,0 - 26,6 16000	16000	15690	13550	34,6 m 10600					
30,0	⊖	4,0 - 30,0 8000	8000	8000	8000						
	⊕	4,0 - 27,2 16000	16000	16000	29,6 m 14000						

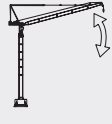

Tragfähigkeiten gültig bis 100 m Hubhöhe. Über 100 m Hubhöhe reduziert sich die Tragfähigkeit um das zusätzliche Seilgewicht.

Lifting capacities valid up to 100 m hoisting height. Over 100 m hoisting height, the lifting capacity is reduced by the additional rope weight.
Capacités de levage valables jusqu'à 100 m de hauteur sous crochet. Au-dessus de 100 m de hauteur sous crochet, la capacité de levage est réduite du poids de câble supplémentaire. / Portate valide fino a 100 d'altezze di sollevamento. Oltre i 100 m si riduce la portata causa il peso addizionale della fune. / Cargas válidas hasta altura de 100 m. Por encima de los 100 m se reduce la carga por el peso adicional del cable. / Cargas válidas até à altura de 100 m. Para além dos 100 m, reduz-se a carga pelo peso adicional do cabo. / Грузоподъемность действительна до 100 м высоты подъема. Свыше 100 м высоты подъема грузоподъемность сокращается на вес дополнительного каната.



	U/min 0 ↔ 0,7 sl./min tr./min	2 x 7,5 kW FU
	2,8 min 2,2 min 1,8 min	45 kW FU 65 kW FU 110 kW FU
	Unterwagen auf Anfrage / Undercarriage on request / Chassis sur demande / Carro su richiesta / Carretón bajo consulta / Chassis sob consulta / Опорная рама по запросу	

	65 kW FU	110 kW FU	110 kW FU
	65 kW FU	65 kW FU	110 kW FU
kVA	143,0	185,0	226,0

kVA reduzierbar bei zu geringer Netz-Anschlussleistung, siehe BAL.
 kVA can be reduced in case of too little power of the mains, see instruction manual. / kVA peut être réduit en cas de trop faible puissance du réseau, voir manuel d'instruction. / kVA riducibili in caso di potenza di rete ridotta (si veda manuale uso e manutenzione) / kVA variable para potencia de red demasiado pequeña, ver Manual de instrucciones. / kVA reduzível no caso de capacidade da rede elétrica muito baixa, ver manual de instruções. / Количество кВА может быть сокращено до минимальной общей потребляемой мощности, см. инструкцию по эксплуатации.

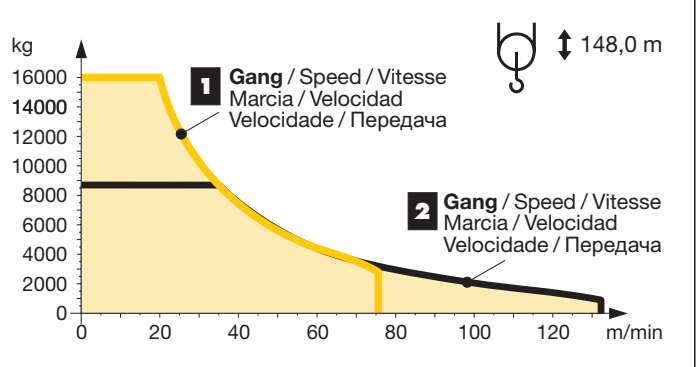
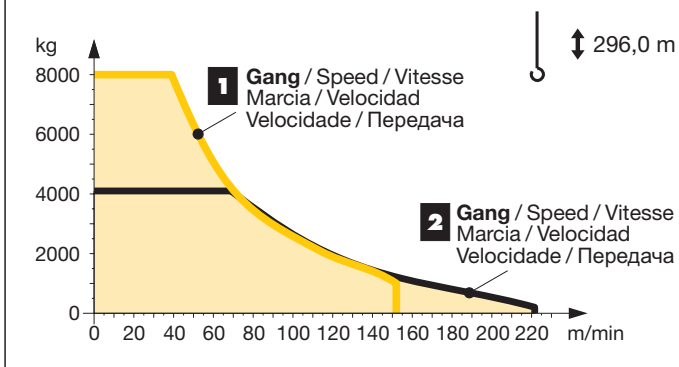
		↔ stufenlos / stepless / régl. continu / régl. progressive / sin escalones sem degraus / бесступенчатый					
65 kW FU WIW 280 VZ 413	max. 874 m	kg	m/min	kg	m/min		
	4 Lagen / Layers Couches / Avvolgimenti Camadas / Capas / Слоёв	1	8000	0 ↔ 39	1	16000	0 ↔ 20
			1000	0 ↔ 152		2800	0 ↔ 76
		2	4100	0 ↔ 69	2	8700	0 ↔ 39
			200	0 ↔ 222		900	0 ↔ 133



		↔ stufenlos / stepless / régl. continu / régl. progressive / sin escalones sem degraus / бесступенчатый					
110 kW FU WIW 300 VZ 407	max. 874 m	kg	m/min	kg	m/min		
	4 Lagen / Layers Couches / Avvolgimenti Camadas / Capas / Слоёв	1	8000	0 ↔ 65	1	16000	0 ↔ 33
			3700	0 ↔ 117		7900	0 ↔ 58
		2	4500	0 ↔ 110	2	9400	0 ↔ 55
			1650	0 ↔ 202		4000	0 ↔ 101
		3	2300	0 ↔ 183	3	5000	0 ↔ 91
			400	0 ↔ 338		1750	0 ↔ 169

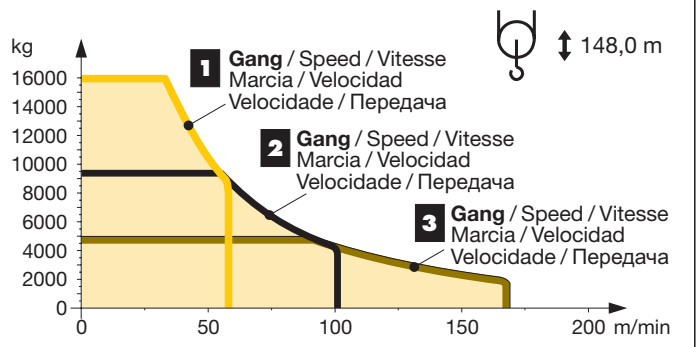
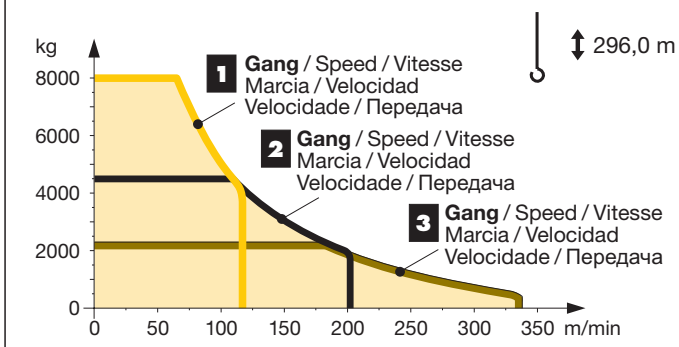

























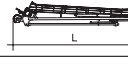

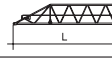

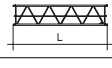

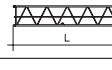

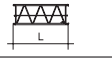

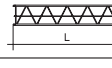

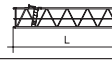

		355 IC					
C 25		Ausleger / Jib / Flèche / Braccio / Pluma / Lança / Стрела					
n		30,0 m	35,0 / 40,0 / 45,0 / 50,0 m	55,0 / 60,0 m	30,0 m	35,0 / 40,0 / 45,0 / 50,0 m	55,0 / 60,0 m
8		52,6	-	-	52,2	-	-
7		46,8	46,8	-	46,4	46,4	-
6		41,0	41,0	41,0	40,6	40,6	40,6
5		35,2	35,2	35,2	34,8	34,8	34,8
4		29,4	29,4	29,4	29,0	29,0	29,0
3		23,6	23,6	23,6	23,2	23,2	23,2
2		17,8	17,8	17,8	17,4	17,4	17,4
1		12,0	12,0	12,0	11,6	11,6	11,6
0	m	6,2	6,2	6,2	5,8	5,8	5,8

		500 HC					
C 25		Ausleger / Jib / Flèche / Braccio / Pluma / Lança / Стрела					
n		30,0 / 35,0 m	40,0 / 45,0 / 50,0 m	55,0 / 60,0 m	30,0 / 35,0 m	40,0 / 45,0 / 50,0 m	55,0 / 60,0 m
10		-	-	-	69,6	-	-
9		64,2	-	-	63,8	63,8	-
8		58,4	58,4	-	58,0	58,0	58,0
7		52,6	52,6	52,6	52,2	52,2	52,2
6		46,8	46,8	46,8	46,4	46,4	46,4
5		41,0	41,0	41,0	40,6	40,6	40,6
4		35,2	35,2	35,2	34,8	34,8	34,8
3		29,4	29,4	29,4	29,0	29,0	29,0
2		23,6	23,6	23,6	23,2	23,2	23,2
1		17,8	17,8	17,8	17,4	17,4	17,4
0	m	12,0	12,0	12,0	11,6	11,6	11,6

Außer Betrieb, Auslegerstellung 15° – 70°. / Out of operation, jib position 15° – 70°. / Hors service, position de flèche 15° – 70°. / Fuori servizio, posizione braccio 15° – 70°. / Posición de pluma, fuera de servicio 15° – 70°. / Posição da lança, fora de serviço 15° – 70°. / Вне работы, положение стрелы под углом 15° – 70°.

¹⁾ **Min. Verankerungshöhe kann bei max. Turmhöhe bzw. bei Hakenhöhe > 100m abweichen.** / Min. anchoring height may deviate at max. tower height resp. hook height > 100 m. / La hauteur d'ancrage min. peut différer en cas de hauteur de mât max. resp. en cas de hauteur sous crochet > 100m. / In caso dell'altezza max torre/gancio, l'altezza min. di ancoraggio può differire di > 100m. / La altura mínima de arriostamiento puede variar con una altura máxima de torre, es decir para alturas bajo gancho > 100m. / Em uma torre, com uma altura do gancho > 100 m a altura mín. do ancoramento pode variar. / Мин. высота крепления к зданию может изменяться при макс. высоте башни или при высоте крюка более 100м.

Kranoberteil		Upper part of crane / Partie supérieure de grue / Parte superiore della gru Parte superior grúa / Parte superior do guindaste / Верхняя часть крана	L (m)	B (m)	H (m)	kg*
Pos. Item Rep Voce Pos. Ref. Pos.	Anz. Qty. Qte. Qta. Cant. Cant. Кол-во	Drehbühne mit KUD-Auflage / Slewing platform with slewing ring support / Ensembles mât cabine avec pivot cage / Piattaforma girevole con supporto della ralla di rotazione / Plataforma giratória com suporte de corôa dentada / Asiento pista con plataforma giratoria / Поворотная платформа с рамой ОПУ				
1	1	355 IC	2,97	2,32	2,56	9290
1	1	500 HC	3,05	2,32	2,57	11350
2	1	Getriebebühne mit Einzieh- und Hubwerk** / Machinery platform with luffing and hoist gear** / Plate-forme des mécanismes avec méc. de relevage et de levage** / Piattaforma meccanismi con argano di sollevamento braccio e argano di sollevamento** / Plataforma de mecanismos con mecanismo de cambio de alcance y mecanismo de elevación** / Plataforma de mecanismos com mecanismos de basculamento da lança e de elevação** / Лебедочная платформа со стрелоподъемным механизмом и грузовой лебедкой**				
			6,74	2,20	2,86	14030
3	1	Getriebebühne mit Einziehwerk, ohne Hubwerk / Machinery platform with luffing gear, without hoist gear / Plate-forme des mécanismes avec méc. de relevage, sans méc. de levage / Piattaforma meccanismi con argano di sollevamento braccio, senza argano di sollevamento / Plataforma de mecanismos con mecanismo de cambio de alcance, sin mecanismo de elevación / Plataforma de mecanismos com mecanismo de basculamento da lança, sem mecanismo de elevação / Лебедочная платформа со стрелоподъемным механизмом, без грузовой лебедки				
			6,74	2,18	2,48	11430
4	1	Hubwerkseinheit** / Hoist gear unit** / Treuil de levage** Gruppo meccanismo sollevamento** / Mecanismo de elevación** 110 kW Grupo de mecanismo elevatório** / Блок грузовой лебедки**				
			2,77	1,88	1,14	2600
5	1	Kabine mit Podest / Cabin with platform / Cabine avec plate-forme / Cabina con pedana / Cabina con plataforma / Cabina com plataforma / Кабина с площадкой				
			5,24	1,94	2,55	1850
6	1	Seitenpodest rechts / Side platform / Plate-forme latérale Pedana laterale / Plataforma lateral / Plataforma lateral Боковая платформа справа				
			2,15	1,17	0,77	100
7	1	Seitenpodest links / Side platform / Plate-forme latérale Pedana laterale / Plataforma lateral / Plataforma lateral Боковая платформа слева				
			3,77	0,90	0,82	180
8	1	Seitenpodest rechts / Side platform / Plate-forme latérale Pedana laterale / Plataforma lateral / Plataforma lateral Боковая платформа справа				
			5,41	1,10	0,82	270
9	1	Auslegerhaltebock / Jib retaining frame / Chevalet de retenue de flèche / Cavallo tirante braccio / Caballete de soporte de pluma / Cavalete de suporte da lança / Кронштейн стрелы				
			11,95	2,20	2,34	5180
10	1	Ausleger-Anlenkstück / Jib heel section / Pied de flèche Sezione articolata braccio / Pluma tramo primero Base articulada de lança / Корневая секция стрелы				
			11,23	1,87	2,04	① 1750
11	1	Ausleger-Zwischenstück / Intermediate jib section / Élément intermédiaire de flèche / Sezione intermedia braccio / Tramo intermedio pluma / Peça suplementar da lança / Промежуточная секция стрелы				
			9,20	1,83	1,98	② 1360
12	1	Ausleger-Zwischenstück / Intermediate jib section / Élément intermédiaire de flèche / Sezione intermedia braccio / Tramo intermedio pluma / Peça suplementar da lança / Промежуточная секция стрелы				
			10,55	1,83	1,98	③ 1500
13	1	Ausleger-Zwischenstück / Intermediate jib section / Élément intermédiaire de flèche / Sezione intermedia braccio / Tramo intermedio pluma / Peça suplementar da lança / Промежуточная секция стрелы				
			5,18	1,83	1,98	④ 850
14	1	Ausleger-Zwischenstück / Intermediate jib section / Élément intermédiaire de flèche / Sezione intermedia braccio / Tramo intermedio pluma / Peça suplementar da lança / Промежуточная секция стрелы				
			10,35	1,83	1,98	⑤ 1330
15	1	Ausleger-Zwischenstück / Intermediate jib section / Élément intermédiaire de flèche / Sezione intermedia braccio / Tramo intermedio pluma / Peça suplementar da lança / Промежуточная секция стрелы				
			10,35	1,83	2,32	⑥ 1430
16	1	Ausleger-Kopfstück / Jib head section / Pointe de flèche Punta braccio / Tramo punta de pluma / Cabeça de lança Концевая секция стрелы				
			11,23	2,23	2,46	⑦ 2720
17	1	Unterflasche / Bottom hook block / Moufle inférieure / Bozzello inferiore Polipasto inferior / Gincho inferior / Крюковая обойма				
			1,05	0,74	1,54	1710
Ballast		Ballast / Lest / Zavorra Lastre / Lastro / Балласт				
18	1	Stahlballast / Steel ballast / Lest en acier / Contrappeso di acciaio Lastres metálicos / Lastro metálico / Металлический балласт				
			4,40	0,31	0,88	4870
19	1	Stahlballast / Steel ballast / Lest en acier / Contrappeso di acciaio Lastres metálicos / Lastro metálico / Металлический балласт				
			4,40	0,27	0,88	2940
Kleinteile		Small parts / Accessoires / Accessori Accesorios / Acessórios / Мелкие детали				
20	1	Seile, Kleinteile / Ropes, small parts / Câbles, accessoires Funi, accessori / Cables, accesorios / Cabos, acessórios / Канаты, мелкие детали				4500

* Einzelgewichte. / Single weights. / Poids individuels. / Singoli pesi. / Tramo punta de pluma / Pesos de peças componentes. / Индивидуальный вес.

** Hubwerk ohne Sekundärbremse / Hoist gear without secondary brake / Mécanisme de levage sans frein secondaire / Argano di sollevamento senza freno ausiliario
Mecanismo de elevación sin freno secundario / Mecanismo de elevação sem freio secundário / Грузовая лебедка без вторичного тормоза

Konstruktionsänderungen vorbehalten! / Subject to alterations! / Sous réserves de modifications! / Riservato il diritto di modifiche strutturali!
¡Sujeto a modificaciones! / Salvo modificação da construação! / Права на внесение конструкторских изменений сохраняются!

Sämtliche Angaben erfolgen ohne Gewähr. / This information is supplied without liability. / Ces renseignements sont sans garantie. / Tutte le indicazioni fornite senza garanzia. / Declinamos toda responsabilidad derivada de la información proporcionada. / Declinamos qualquer responsabilidade quanto à informação fornecida. / Все данные указаны без обязательств.